

Supplier Manual



Supplier Manual (Vers. 02/2016) read and accepted:

.....
(Date, signature, company stamp)

Kindly return the signed sheet to the management of SIMPEX.

Table of Contents

| | |
|---|-----------|
| 1 FOREWORD | 2 |
| 2 GENERAL INFORMATION AND GLOSSARY | 3 |
| Supplier's persons of contact..... | 3 |
| SIMPEX's persons of contact..... | 3 |
| 3 PRODUCT REQUIREMENTS | 5 |
| 3.1 Labeling requirements for shipping units..... | 5 |
| 3.2 Issuing of test reports: | 6 |
| 3.3 Product labeling | 7 |
| 3.3.1 SIMPEX Sticker (EU):..... | 7 |
| 3.3.2 SIMPEX sticker Non – EU:..... | 8 |
| 3.4 Labeling of textile items | 9 |
| 4 SAMPLE SHIPMENT | 10 |
| 5 LOGISTIC REQUIREMENTS | 11 |
| 5.1. General information | 11 |
| 5.2. Marking of GVE and outer carton | 12 |
| 5.3. GS1 Transportetikett (GS1- 128 Strichcode, SSCC) | 13 |
| 5.4. Barcode quality | 15 |
| 5.5. Incomplete / wrong labels / tags | 15 |
| 5.6. Logistical requirements for cargo carriers for delivery trucks | 16 |
| 5.7. Empty packaging handling | 17 |
| 5.8. Loading the pallets | 18 |
| 5.9. Quality/condition of the cardboard:..... | 18 |
| 6. QUALITY ASSURANCE | 20 |
| 7. OVERVIEW LOGISTICS CONTRACTUAL PENALTIES | 21 |
| 8. CHECK LIST FOR LOGISTIC REQUIREMENTS | 23 |

1 Foreword

Competition on the international markets has become increasingly aggressive in the retail sector over the past years. Increased customer expectations along with low price elasticity present large challenges for our company and ultimately here, in the field of logistics in regards to quality, on-time delivery and flexibility.

The quality of logistics and overall goods processing determine to a large extent the competitiveness of the product ranges for our customers (these are all national organizations and their individual distribution channels). This quality presents a fundamental strategic success factor for you and our company.

This supplier manual is intended to help to optimize the entire value-added chain area, and to structure all business processes efficiently, at high quality and customer-oriented through the cooperative and integrated actions of all persons involved in the processes from procurement to the delivery to the customer.

It is the sole duty of the supplier - without prejudice to the standards contained in this manual - to ensure that the products supplied comply with the Cooperation Agreement, and meet the governance requirements of Austria, ASPIAG countries and the EEA. Information contained in this manual is not intended to be exhaustive.

Additions or deviations may occur from case to case and as necessity arises between SIMPEX and the suppliers. The contact persons mentioned in this document will readily provide you with the information you need.

This supplier manual is an integral part of the Cooperation Agreement.

SIMPEX Import Export GmbH
Europastraße 3
A – 5015 Salzburg
Email: office@SIMPEX.at

2 General Information and Glossary

In order to structure the processes consistently in accordance with the above mentioned outline, efficient communication among the individual stakeholders is the key factor of success and quality. Vital therefore are:

- Compliance with and observance of all agreements
- Prompt individual initiative, information in case of deviations, changes to all delivery relevant issues

Supplier's persons of contact

The persons responsible for the logistic handling on the part of the supplier must be nominated by the supplier (contact person, representative, manager, each person with email, telephone and fax).

This information must be forwarded immediately to SIMPEX, Wiener Neudorf, via email (office@simpex.at).

SIMPEX's persons of contact

For all questions regarding the listed topics the following contact persons are available:

Registered Office / Purchasing / Quality Management

| | | |
|---------------------------|----------|--------------------|
| SIMPEX Import Export GmbH | Telefon: | +43 662 4470 77050 |
| Europastr. 3 | FAX: | +43 662 4470 519 |
| A – 5015 Salzburg | | |

Logistics /Administration Office

| | | |
|---------------------------|----------|--|
| SIMPEX Import Export GmbH | Telefon: | +43 662 4470 39535 |
| Industriezentrum NÖ-Süd | FAX: | +43 662 4470 39550 |
| Straße 14, Objekt 24 | E-Mail: | office@SIMPEX.at |
| A – 2355 Wiener Neudorf | | |

Invoice recipient

SIMPEX Import Export GmbH Europastr. 3
A – 5015 Salzburg

| | |
|-----------------------------|----------------------------------|
| Company Identification No.: | ATU 58350705 |
| Commercial Register: | FN 226834f |
| Tax ID.: | 040/8285 Finanzamt Salzburg (91) |
| ARA Nr.: | 5010 |
| Bank: | Bank Austria |
| BIC: | BKAUATWW |
| IBAN: | AT191200084014701593 |

Additional invoice recipient (for customs clearance) SIMPEX Import Export GmbH
Industriezentrum NÖ-Süd Straße 14, Objekt 24
A – 2355 Wiener Neudorf

Consignee

SIMPEX Import Export GmbH Industriezentrum NÖ-Süd Straße 14, Objekt 24, Tor 04 A –
2355 Wiener Neudorf

Notification of goods dispatch:

To obtain the accurate delivery date please contact in writing: wareneingang@SIMPEX.at

Glossary:

EVE – single package unit (Einzelverpackungseinheit) GVE – bulk package unit
(Grossverpackungseinheit)
EMC – electromagnetic compatibility
EUL – efficient unit loads
ETA – estimated time of arrival
ECR – Efficient Consumer Response
SSCC - Serial Shipping Container Code

3 Product requirements

3.1 Labeling requirements for shipping units

When confirming the order of an item, the supplier commits to satisfy all of the following points: All delivered items must be marketable in Austria, the EEA and in the target destination as per order.

- All products must comply with the European standards and the specific state laws in terms of sales packaging and declaration and also composition.
- The supplier must provide all necessary certificates upon request.
- All operating instructions, safety and care information, material markings (□textile industry: laundry symbols, etc.), and also descriptions on and inside the package must be translated in any national language referred to or quoted. In addition to this, all operating instructions must be marked with the corresponding country code □example: SI comes before the Slovenian translation.
- The supplier is responsible for the proper translations of all texts.
- Our SIMPEX stickers or hangtag default data (available for download at www.SIMPEX.at) must be applied to each and every sales packaging.
- The requirements set out in Article 5 regarding transport packaging must be implemented without exception by the supplier.
- Any technical goods and hardware must be accompanied by a certificate of warranty complying with the legal requirements of the respective countries (the warranty period in particular is different in each country). This can be incorporated into the operating instructions or enclosed separately. The supplier remains solely responsible for the correctness of the warranty cards.
ATTENTION: There are specific national requirements for Hungary and Slovenia!
- The crossed out trash bin must be present on every electrical product and on any battery-powered product. The meaning and symbol must be explained accordingly within the operating instructions. We would like to alert you here that the wording of the explanation is subject to strict requirements particularly in Italy.
ATTENTION: Each country also has different requirements for this!
- All products must be marked with the respective relevant pictograms and / or the new hazard symbols (including the GHS hazard statements).
- We reserve the right to refuse the acceptance of goods or to return the goods, to rework the goods using third parties and to invoice all costs incurred thereof appropriately, if contrary to expectation one of the aforementioned points is not met satisfactorily. Nevertheless, Article 10 of the Cooperation Agreement shall apply.

3.2 Issuing of test reports:

For electrical appliances the following test / inspection reports must be made available:

- CE Declaration and noise emission values
- EMC Test Report
- Safety Report
- Declaration of conformity

Reviews and reports must be sent to SIMPEX by the supplier on his/her own accord **in full**, indicating the **SIMPEX item number and model number**.

- If the model number of the report or the certificate differs from the one on the item, we will need an identity verification, incl. date, company stamp and signature.
- Dates on the EMC Test Reports and Declarations of Conformity must be **identical**.
- Declarations of Conformity must relate to the appropriate and applicable regulations and laws with regard to contents.

3.3 Product labeling

Each product must have the SIMPEX sticker shown below incorporated on the sales packaging or the given data incorporated on the sales packaging.

Two different stickers are available:

EU sticker: Products manufactured within the EU

Non-EU sticker: Products manufactured outside the EU

The SIMPEX sticker must include the following data:

- Product names in all national languages
- Barcode EAN 13
- The specified importer details
- Manufacturer information including address

Both stickers can be downloaded from the homepage www.SIMPEX.at.

The size of the sticker must be adapted to the product (the sticker template is not the original size).

3.3.1 SIMPEX Sticker (EU):

| | |
|--|-----------------|
| (A) (I) (H) (SLO) (HR) | |
| Simpex article number XXXX | Size XXX |
| article description in GERMAN language <input type="checkbox"/> | |
| article description in ITALIAN language | |
| article description in HUNGARIAN language | |
| article description in SLOVENIAN language | |
| article description in CROATIAN language | |
|  | |
| Herkunftsland: Country of Origin in GERMAN language Paese di provenienza: Country of Origin in ITALIAN language Származási ország: Country of Origin in HUNGARIAN language Država izvora: Country of Origin in SLOVENIAN language Zemlja podrijetla: Country of Origin in CROATIAN language | |
| Hergestellt für: / Prodotto per: / Gyártva: / Proizvedeno za / Proizvedeno za: SIMPEX Import Export GmbH, Europastraße 3, 5015 Salzburg, Österreich | |
| Forgalmazó: SPAR Magyarország Kereskedelmi Kft., H-2060 Bicske, SPAR út, www.spar.hu Prodaja: SPAR Slovenija d.o.o., Letališka cesta 26, 1000 Ljubljana, Slovenija, www.spar.si Stavlja na tržište RH: SPAR Hrvatska d.o.o., Slavonska avenija 50, 10000 Zagreb, Hrvatska, www.spar.hr | |

*Replace red marked text accordingly to the item

3.3.2 SIMPEX sticker Non – EU:

| | |
|---|-----------------|
| (A) (I) (H) (SLO) (HR) | |
| Simpex article number XXXX | Size XXX |
| article description in GERMAN language <input type="checkbox"/> | |
| article description in ITALIAN language | |
| article description in HUNGARIAN language | |
| article description in SLOVENIAN language | |
| article description in CROATIAN language | |
|  | |
| Herkunftsland / Paese di provenienza / Származási ország / Država izvora / Zemlja podrijetla Country of Origin in GERMAN language / Country of Origin in ITALIAN language / Country of Origin in HUNGARIAN language / Country of Origin in SLOVENIAN language / Country of Origin in CROATIAN language | |
| Importeur / Importato da / Importőr / Uvoznik / Uvoznik: SIMPEX Import Export GmbH, Europastraße 3, 5015 Salzburg, Österreich | |
| Forgalmazó: SPAR Magyarország Kereskedelmi Kft., H-2060 Bicske, SPAR út, www.spar.hu Gyártó: Indication of producer (name & exact address) Prodaja: SPAR Slovenija d.o.o., Letališka cesta 26, 1000 Ljubljana, Slovenija, www.spar.si Stavlja na tržište RH: SPAR Hrvatska d.o.o., Slavenska avenija 50, 10000 Zagreb, Hrvatska, www.spar.hr | |

*Replace red marked text accordingly to the item

Goods with an incomplete or even missing SIMPEX sticker will not be accepted. The supplier must collect and rework incompletely labeled goods.

For each calendar week, the supplier will be charged a storage fee of € 2.00 and a handling fee of € 25 per pallet for the duration the goods remain in storage for pick up by the supplier.

3.4 Labeling of textile items

All textile items must be identified by an additional SIMPEX sticker containing the following information:

Material description
Laundry and care instructions
Shrinkage value
Sample sticker: } in every national language

| | |
|---|--|
| <p>Materialzusammenstellung: Deutsch</p> <p>Italienisch</p> <p>Slowenisch</p> <p>Kroatisch</p> <p>Ungarisch</p> <p>Waschanleitung / Pflegehinweise (Symbole):</p>  <p>Schrumpfwert</p> | <p>Material composition: German</p> <p>Italian</p> <p>Slovenian</p> <p>Croatian</p> <p>Hungarian</p> <p>Laundry instructions / care advice (symbols):</p> <p>Shrinkage value</p> |
|---|--|

In case of non-compliance, all internal as well as external expenses incurred on the part of SIMPEX are subject to subsequent charging.

4 Sample shipment

Every supplier is obliged to send free **sample patterns**, **production samples** and **photo samples** of the ordered items to the respective address below.

Sample patterns are those patterns which are a decisive factor for ordering an item. These must be sent to the address below according to the demands of the respective purchasing department, and if possible, in its original presentation:

Delivery address:

SIMPEX Import Export GmbH
IZ-NÖ SÜD
Straße 14, Objekt 24, Tor 4
A – 2355 Wiener Neudorf

Kindly mark the EVE as a “Sample pattern”!

Production samples (final samples) are initial production samples. The products should be in their original presentation and all stickers, markings, labels and instructions as required by SIMPEX must be present.

Delivery address:

SIMPEX Import Export GmbH
Musterzimmer/ Attn. the respective contact person
Europastraße 3
A-5015 Salzburg, Austria
Tel.: +43 662 4470 47957

Kindly mark the EVE with “Final sample”!

Photo samples are **not** pictures but original products. Those are required for the fliers in the respective countries. The quantity of required samples is indicated in the order.

Delivery address:

SIMPEX Import Export GmbH
FOTOMUSTER
IZ NÖ Süd, Strasse 14, Objekt 24
A – 2355 Wiener Neudorf
Tel.: +43 662 4470 39535

Kindly mark the EVE with a copy of the SIMPEX order and as “Photo sample”.

Deviations from the ordered item must be affixed to the EVE. Moreover, SIMPEX reserves the right to request suitable photos (min. 300dpi) for advertising purposes from any supplier.

ATTENTION:

Observing the date of dispatching the samples is binding. The respective competent department must be informed immediately about any delay!

5 Logistic requirements

All goods delivered to SIMPEX must meet each and every of the following logistic requirements

5.1. General information

- All goods must be delivered in the **right quantity, at the right time and according to the agreed quality**.
- Each EVE must be marked with the **EAN 13 barcode** (see Article 5.4. Barcode)
- **GVEs** must be marked with the **EAN 13 barcode** (see Article 5.4. Barcode quality). Items with a date of expiry must be marked with the **EAN 128 barcode** (see Article 5.4. Barcode quality)
- Outer carton, GVE and EVE must have a different barcode each; That is, **a barcode may not be duplicated** (the same barcode on EVE and GVE is not acceptable)¹
- The **cardboard packaging must be sturdy**, so that goods inside are not damaged. (see Article 5.9. Carton quality)
- Pallets must not be taller than **max. 2 m incl. the pallet** when delivered. .
- GVEs must also be **EUL-compliant** and goods must not protrude or overhang from the pallet. The supplier is obliged to load the pallet in a way that safe and steady transportation is ensured and the cartons on the pallets can also be stored in pallet rack systems.
- The **pallets must be loaded homogenously**, that is, with one product only per pallet.
- Also inside the **containers goods must be of single variety**. If different items are inside the container, those must not be mixed but must be clearly separated from each other.
 - SIMPEX reserves the right to refuse the acceptance of goods, if the pallets are not homogenous, and different items inside the container are not clearly separated from each other; or SIMPEX will at least invoice the supplier for the pick out (€ 50,-- per man hour).
- **Only transparent packaging wraps** must be used – never use black foils.

¹ www.gs1austria.at

5.2. Marking of GVE and outer carton

GVE Label

A sticker with the following information must be affixed to each GVE:

- EAN 13 for items without date of expiry
- EAN 128 for items with date of expiry
- SIMPEX item number
- Supplier item number
- Item description (German or English)
- Dimensions (L x W x H)
- Gross weight
- Pieces per export carton

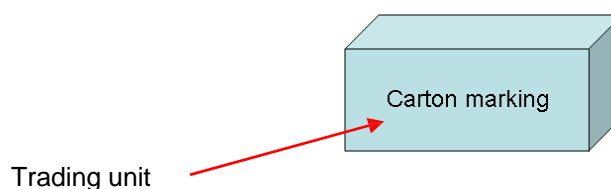

Labeling of cartons must be done on two sides.

It is mandatory that all outer cartons are equipped with the following

- SIMPEX item number
- Supplier item number
- Item description (German or English)
- Dimensions (L x W x H)
- Gross weight
- Pieces per export carton
- Sticker with the words: **“Achtung Auspackartikel“ (Attention Packaged Product)**

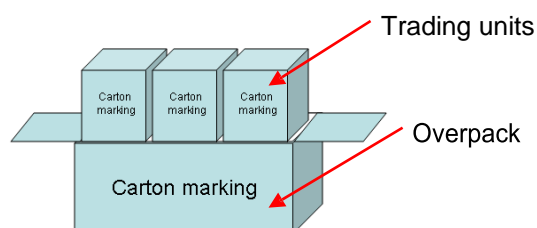

5.3. GS1 Transportetikett (GS1- 128 Strichcode, SSCC)

The pallet label must include the following data:

| | |
|--|-----------|
| SSCC of the pallet | AI (00) |
| GTIN of secondary packaging (GVE) | AI (02)* |
| Batch number | AI (10)** |
| Quantity of secondary packages (GVE) on the pallet | AI (37) |

ATTENTION: If the item has a best-before date ensure that also the BBD on GS1- 128 (on both, the transport label and the GVE) is represented as follows:

AI (15) BBD in the format DDMMYYYY

*GTIN of secondary packaging: it is absolutely necessary to show the GVE-GTIN or the GTIN of the purchase unit on the GS1 transport label. Representation of a GTIN deviation, such as the. GTIN of the outer packaging, is not permissible.

** Batch number, if available.

X-module width / barcode height: label format: (recommendation)

Width: 0.435 – 1.016 mm DIN A 5 210 x 148 mm (H x W)

Height: Not less than 32mm (DIN A 6148 x 105 mm (H x W))

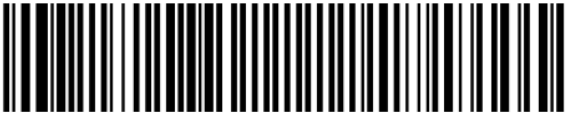
| Musterlieferanten GmbH A-9999 Musterstadt | <u>Sample Label</u> |
|--|---|
| SSCC 390123450000000012 | Sample Supplier AA-9999 Sampletown |
| GTIN Menge 9012345678906 50 | SSCC |
| Haltbarkeitsdatum Charge 01.05.2006 1234 | GTIN Quantity |
| Musterartikel 6x125g | Best-before date Batch |
|  (02) 09012345678906 (15) 060501 (37) 50 | Sample Item 6x125g |
|  (00) 390123450000000012 (10) 1234 | |

| | |
|--------------------|---|
| (02) | Application Identifier (AI) for the GTIN of the trade units on the pallet |
| 09012345678906 | GTIN of the trade unit (number of secondary packaging, GVE) always combined with AI (37). Structure of the GTIN: "0"= Indicator of goods with same target weight 0-9; "901234567890" = GS1- basic number + product reference; "6" = check digit |
| (15) | Application Identifier (AI) for the best-before date |
| 060501 | Best-before date (YY/MM/DD) |
| (37) | Application Identifier (AI) for the number of trade units on the pallet |
| 50 | Number of trade items on the pallet |
| (00) | Application Identifier for the SSCC |
| 390123450000000012 | SSCC. Structure of SSCCs: "3" = Extension digit 0-9; "9012345000000001" = GS1 Basic number with serial reference number; "2" = Check digit |
| (10) | Application Identifier (AI) for the batch number |
| 1234 | Batch number |

Placement of pallets labels:

According to the ECR manual the GS1:128 label must be applied by measuring 400 to 800 mm from the ground and sideward in at least 50 mm from the edge. Pallets which are stretched wrapped for stability during transportation must have the label affixed outside on the stretch wrap. The label must be applied twice on the narrow edge and on the right hand side on the long side of the pallet.

It is permissible to fold the text field over, if the pallet is small; however, it must be possible to scan the part of the barcode without additional manipulative handling.

(see also ECR Documentation "Harmonization GS1- 128 – GS1 Transport Label")

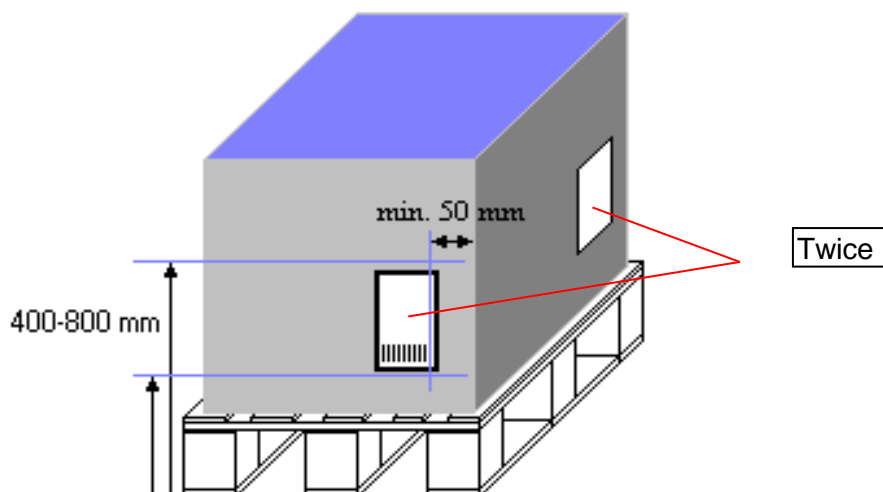

Multiple stacked pallets, which are stacked on each other for transportation, will need to have individual (each pallet its own) SSCC labels affixed.

If EPAL-pallets are not used for delivery but containers are used instead, printed pallet labels sufficient for the entire delivery volume must accompany the delivery.

5.4. Barcode quality

In order to ensure fast and efficient scanning at the cash desks and in retail and wholesale, the following quality is required for barcodes:

The applied barcode symbol must at least show the following overall symbol grade in accordance with ISO/IEC 15416:

| | |
|--------------------|------------|
| EAN-13/UPC-A: | 1.5/06/670 |
| GS1-128 (EAN-128): | 1.5/10/670 |

Here 1.5 is the overall classification symbol; 06 or 10 is the reference number of the aperture and the 670 nanometers is the wavelength of light.

The symbol design must comply with the respective specifications of the barcode symbology:

| | |
|---------------------|--|
| EAN-13/EAN-8/UPC-A: | as per GS1 Specifications or ISO/IEC 15420 |
| GS1-128 (EAN-128): | as per GS1 Specifications or ISO/IEC 15417 |

More information about the barcode's width and height can be found on www.gs1.at.

SIMPEX recommends an overall symbol classification of 2.5 in order to ensure the best possible legibility of barcodes.

In those cases where barcodes do not feature the minimum overall symbol grade 1.5 as per ISO/IEC 15416 which is required by SIMPEX, SIMPEX reserves the right to charge the supplier Euro 0.37 per affected GVE label and Euro 5 per affected pallet label.

GS1-Austria (www.gs1.at) can verify whether the barcode meets the quality requirements. The barcode can also be checked in regards to quality by SIMPEX.

5.5. Incomplete / wrong labels / tags

If labels are missing or are incomplete or wrong (this applies to the marking of the EVE as well as the GVE and/or export cartons and outer cartons) upon delivery, the supplier may be required to rectify or relabel the logistic units. Following a notification from SIMPEX, the supplier must collect the entire article without delay, correct and deliver it again (after coordinating a new delivery date with SIMPEX). The supplier will be charged a storage fee of € 2.00 and a handling fee of € 25 per pallet for each calendar week the goods remain in storage awaiting pick up by the supplier.

5.6. Logistical requirements for cargo carriers for delivery trucks

1. Requirement: use of standardized reusable pallets

Only EURO-pallets dimensioned:

- Length 1.20 m
- Width 0.80 m

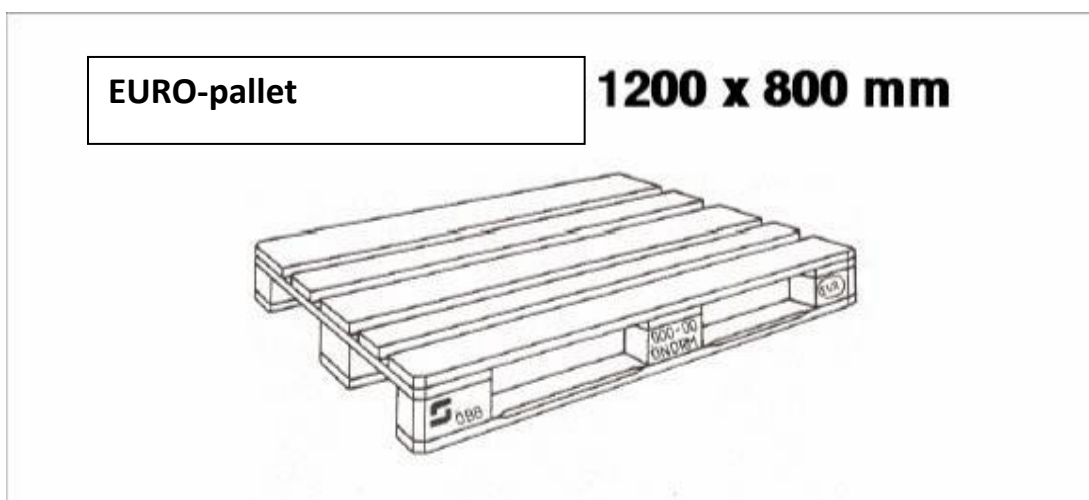

2. Requirement: Adhere to the maximum loading height

- Pallet overhang max. 3 cm
- Maximum pallet height (including pallet): 2 m

5.7. Empty packaging handling

The delivered number of reusable pallets is replaced directly when the truck is unloaded, unless agreed differently.

If a pallet swap is not possible, the freight company / supplier will receive an empty pallet slip accounting for the number of pallets that were not replaced.

ATTENTION: This pallet slip is issued to the supplier (not the freight company) and must be redeemed within the next 3 months; thereafter it is rendered null and void and the supplier will not be able to reclaim his/her EURO-pallets.

Damaged pallets and those which cannot be used any longer will not be replaced, if:

1. A board is missing, or shows lateral or transverse breakage.
2. A leader board (top or bottom board) is so splintered that more than one nail or screw shaft are noticeable.
3. More than two leader boards (top or bottom board) are so splintered showing each one nail or screw shaft.
4. A block is missing, broken or splintered and more than one nail or screw shaft are noticeable.
5. A minimum of one symbol of the railway / pallet organization is not shown and the sign "EUR" is missing.
6. It is obvious that unapproved parts were used for repair (e.g. boards or blocks that are too thin, too narrow, too short).
7. General condition is so poor that the load capacity cannot be guaranteed any longer (e.g. rotten, brittle boards/blocks etc.) or can harm the loaded goods.

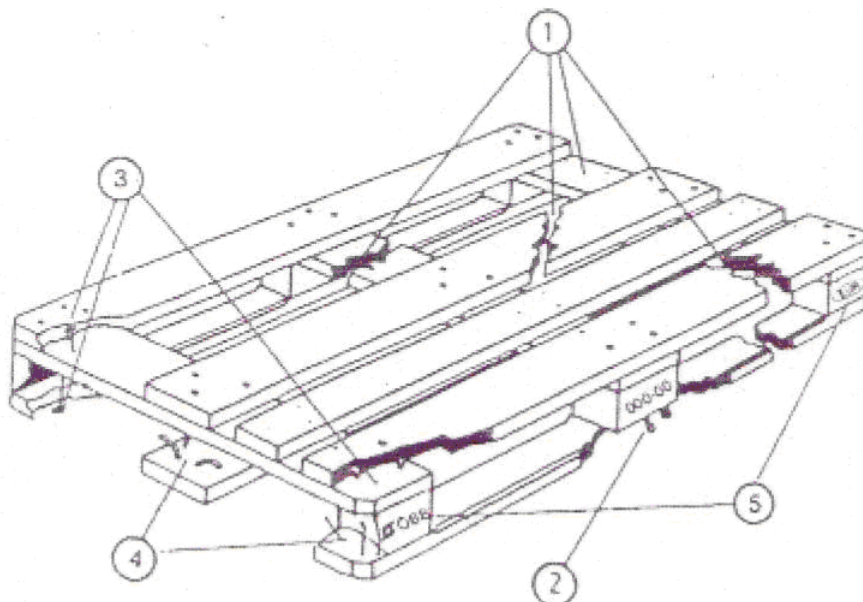

5.8. Loading the pallets

The pallets must be loaded homogenously; that is, only one product per pallet!

5.9. Quality/condition of the cardboard:

Standard is that goods are delivered in cartons or secondary packaging, which must show the weight of the goods and the stacked cartons on it. SIMPEX reserves the right to refuse the acceptance of goods in damaged cartons. If this is the case, the supplier must pick up the goods, repack into sturdy cartons and redeliver them to SIMPEX.

Nevertheless, SIMPEX is entitled to demand a no-fault penalty amounting to 5% of the goods value of poorly packaged goods, a minimum however, €1,000 per item, if inferior cardboard packaging results in impacting the sorting and picking processes of goods.

Detailed information about cardboards

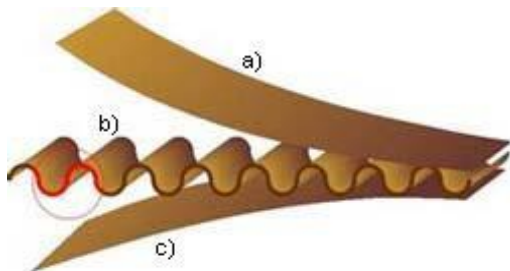

Example of cardboard composition:

- a) Top sheet of liner board: CCNB 250 gsm
- b) Corrugated cardboard: 115 gsm
- c) Bottom sheet of liner board: 250 gsm

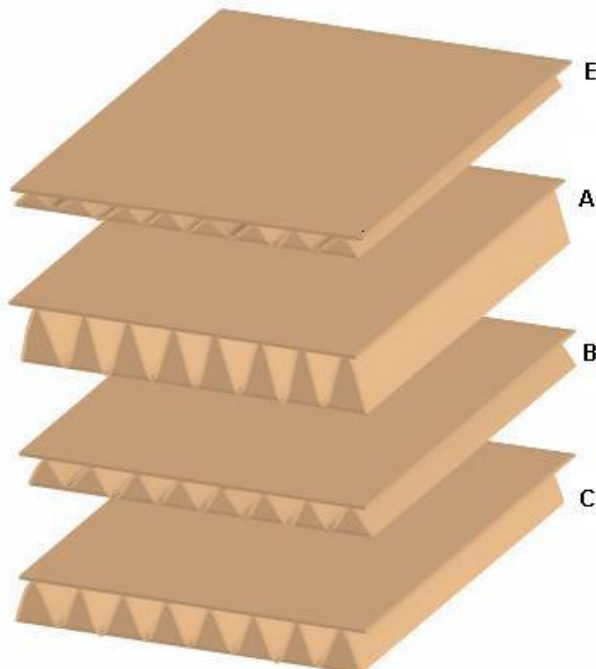

Corrugated cardboard design:
Commonly used are: A, B, C and E designs, distinguished by size:

A – ca. 5mm B – ca. 3mm C – ca. 4mm
E – ca. 1.5mm

BC design with double wall - ca. 6mm
(combination of the B + C design)

Corrugated cardboard features 2 main types:

- Single wall (3 layers) is made of top and bottom sheets and the flute.
- Double wall (5 layers) is made of 3 sheets of liner board and 2 layers flutes.

The orientation of the cardboard must be observed to ensure the strength of the carton.

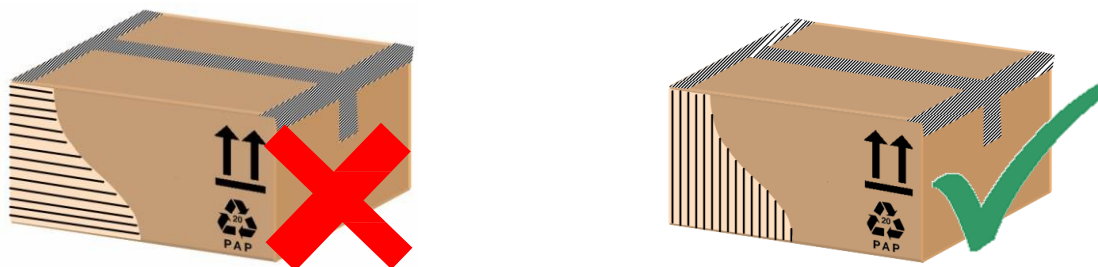

A cardboard quality that is suitable for the contents must be chosen, so that under normal usage conditions no transport damages are expected to occur. Moisture, for instance, which has a negative impact on the properties of the carton during transport, must also be taken into consideration.

For that reason keep an eye on a safety backup when choosing a carton.

6. Quality assurance

The supplier is obliged to provide all relevant documents that are required for the product within 10 days after the order confirmation. Clear assignability to the product and timeliness must be guaranteed. Certificates where a testing service provider has assigned a period of validity make it necessary that documents are furnished with an expiration date in order to ensure the currency of the documents.

The supplier must provide in particular the following documents in due time:

- Product data sheets
- Safety data sheets
- Technical data sheets
- (CE) Test reports
- Declarations of conformity
- Certificates to confirm the eco-social standards in the production plants (e.g. BSCI)

7. Overview logistics contractual penalties

Disregarding the above mentioned requirements leads to serious issues in respect to the supply chain and hinders or fully prevents the purchase of products, therefore we reserve the right to invoice the following penalties/costs. In any case, however, the right to lodge a claim for further-reaching damages is not excluded.

| Omission | In addition to penalty | Penalty in % goods value / additional costs |
|---|---|--|
| No/incomplete labels, tags or SIMPEX stickers | NO GOODS ACCEPTANCE and pick up of goods by supplier and subsequent performance | Storage fee € 2.00 per each pallet per calendar week the goods are stored awaiting pickup by the supplier. |
| Obstruction of sorting/picking due to inferior cardboard | NO GOODS ACCEPTANCE and pick up of goods by supplier and subsequent performance | 5% of the goods value of poorly packaged goods, at least however, €1,000 per item (if this is a hidden defect which is not apparent upon goods acceptance) |
| Delivery without notification or delayed or incomplete notification. | GOODS ACCEPTANCE as an exception (OK needed from SIMPEX) | Penalty acc. to Article 5. of Cooperation Agreement + further charge of incurred additional costs, min. €300 |
| Pallets or container are not homogenous | GOODS ACCEPTANCE as an exception (OK needed from SIMPEX) | Charge of additional costs (€ 50 per man hour) for homogenous sorting |
| In case of justified withdrawal on part of SIMPEX due to supplier's delay | | Penalty acc. to Article 6.1. of Cooperation Agreement |
| Deviation from delivery ratio greater than +/- 5% | | Penalty acc. to Article 6.1. of Cooperation Agreement |
| Early and late delivery | GOODS ACCEPTANCE as an exception (OK needed from SIMPEX) | Contract penalty acc. to Article 6.2. or 6.3. of Cooperation Agreement, in addition to pallet fee of € 2.00 net each for storage of goods on required pallets in case of early delivery. |
| Short delivery | | Contract penalty acc. to Article 6.4. of Cooperation Agreement + further charge of incurred additional costs, min. €300 |
| Excess delivery | | Further charge of incurred additional costs, min.€300 |
| No scannable EAN´s | | Per delivered EVE or GVE, where scanning of EAN 13 or GS1- 128 are not feasible, € 0.37 and € 5.00 per affected pallet label |
| Violation of quality assurance duties | | Penalty acc. to Article 16. of Cooperation Agreement |

In general SIMPEX reserves the right to invoice administration fees amounting to € 50, for efforts arising due to the deviation from the named requirements. We reserve the right to increase the amount invoiced by a handling fee of 20%, if rework is handed over to third parties.

8. Check list for logistic requirements

In order to ensure the smooth flow of the goods delivery, we would like to recap the key points in an overview.

This overview is intended to serve as a guide; it is not meant however, to exclude any of the other contents mentioned in this Logistics Manual or the Cooperation Agreement from being implemented.

GENERAL REQUIREMENTS:

- ✓ Notification of goods delivery must take place on time prior to delivery.
- ✓ Ensure completeness of the logistic documents / accompanying documents when delivering.

EVE REQUIREMENTS

- ✓ SIMPEX sticker (NOT EU / EU sticker) on EVE
- ✓ Marking of EVE in all national languages incl. international country codes
- ✓ Representation of all legally relevant pictograms on EVE
- ✓ Operating instructions in all national languages must be included in the EVE
- ✓ Warranty cards in all the languages must be included in the EVE

GVE REQUIREMENTS

- ✓ EAN codes on EVE / GVE must be different
- ✓ EAN codes must be readable
- ✓ Correct stickers on every GVE incl. SIMPEX item number
- ✓ Outer carton of packaged items must be marked with "ACHTUNG AUSPACKARTIKEL" (ATTENTION PACKAGED ITEM).